



LEGENDS OF

CHIMA

TM

70130



1



2



3



4





1

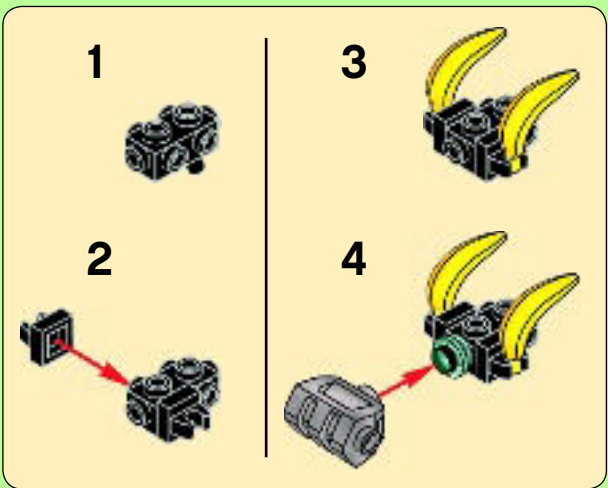

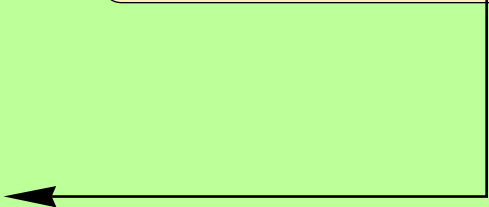
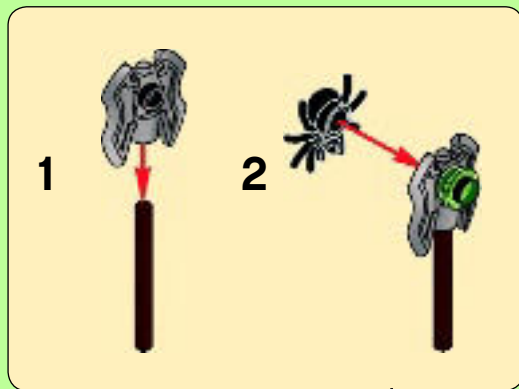



1x

1



1x



2x

2



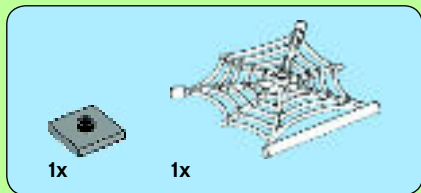

3



6



4





1

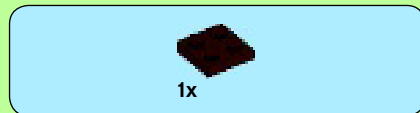
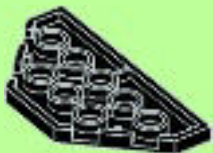

2





3

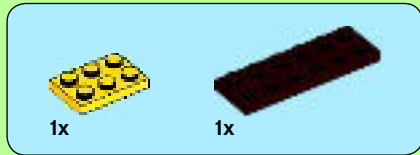

4



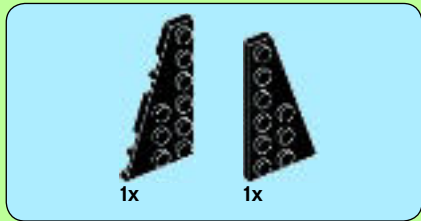

5

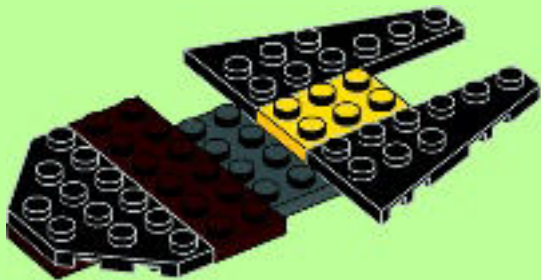

6





2x



2x



2x

9

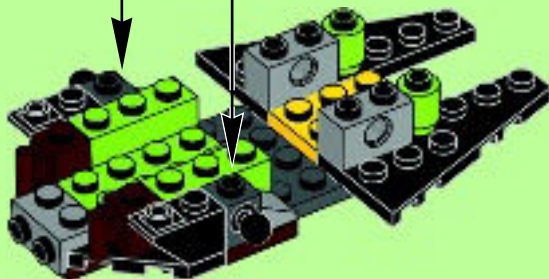
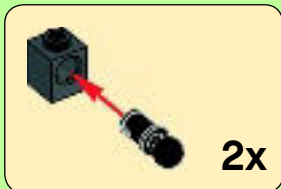



1x

10



12



2x



2x

11

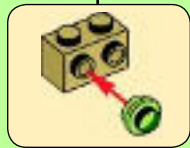
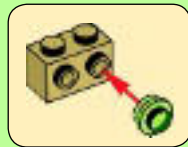



2x



2x

12



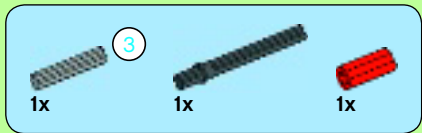

1

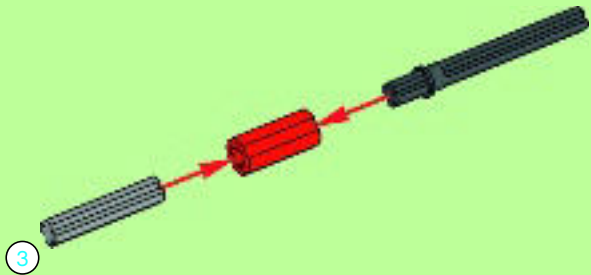

14

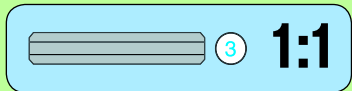

2





1x



1x

3

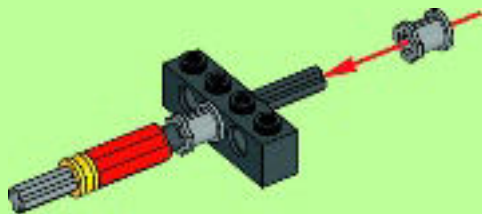

1x



1x

4

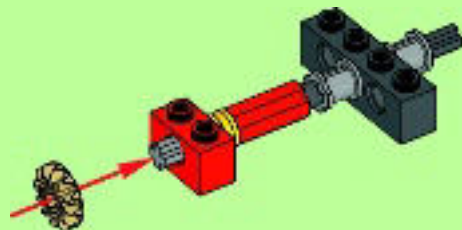



1x



1x

5

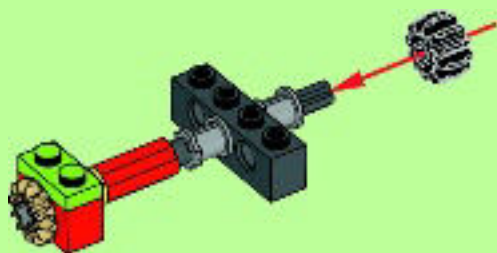

13

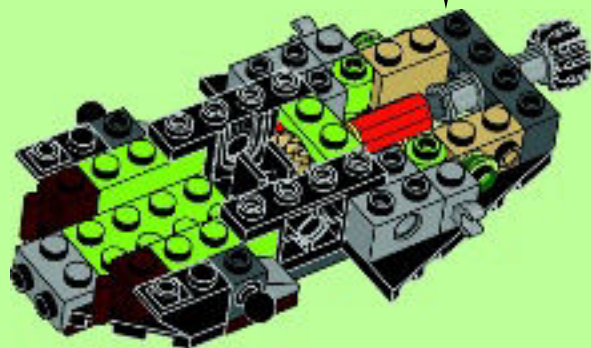



1x

14

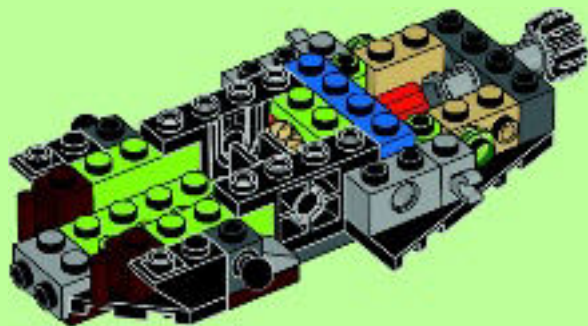

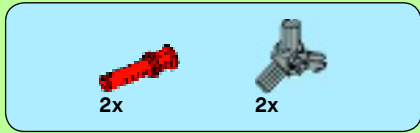

17

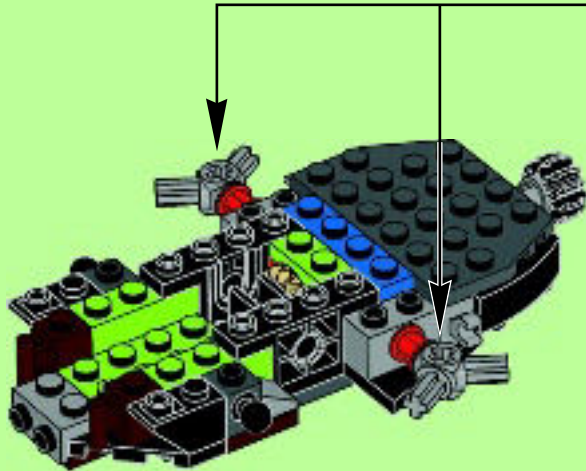



1x



1x



1x

19

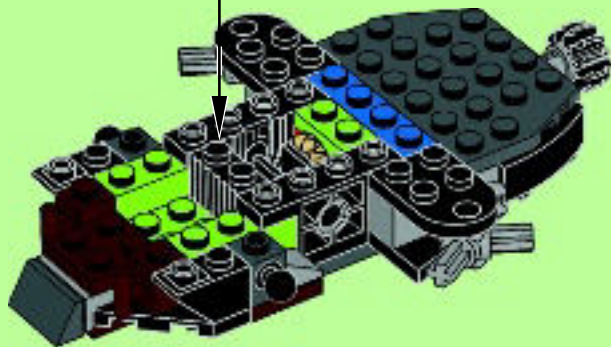



2x



2x

20

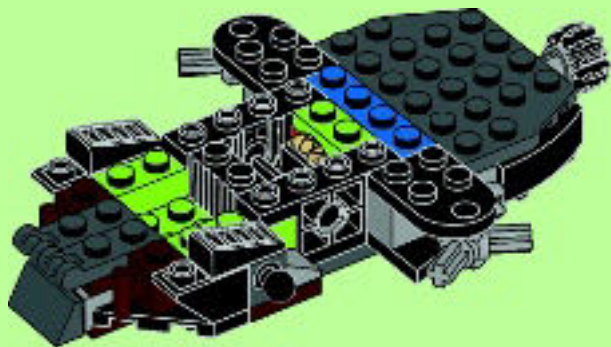



21

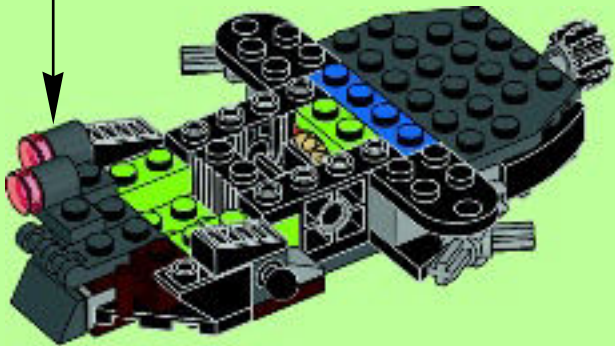



22

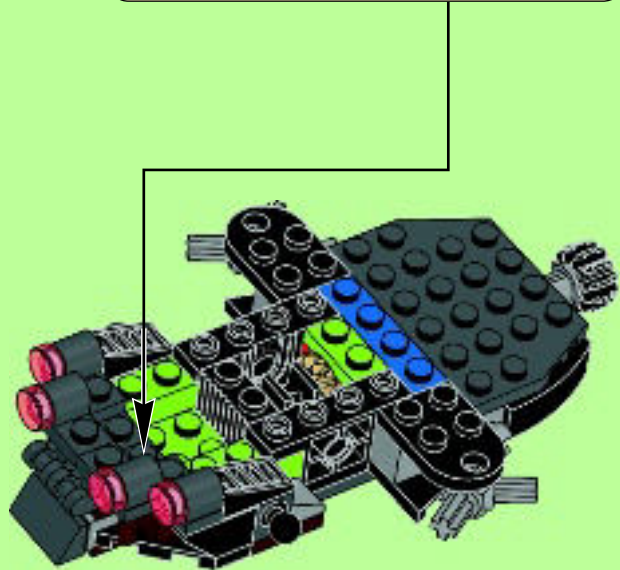



2x



1x

23

1



2

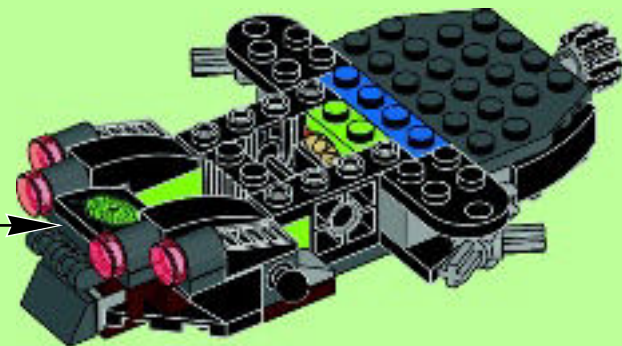



2x



2x

24

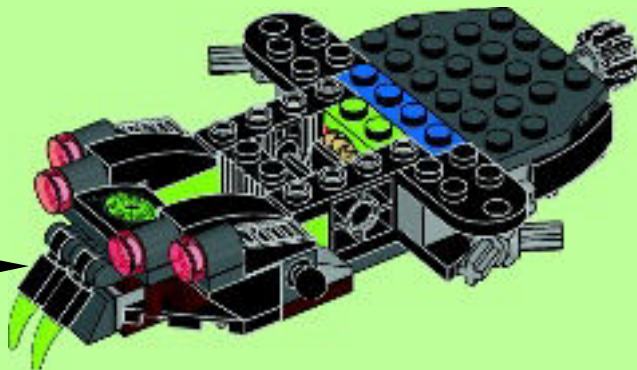
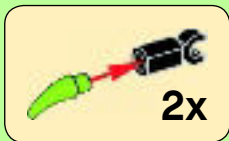



2x



2x

25

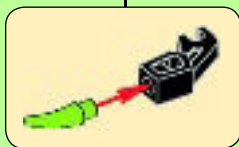
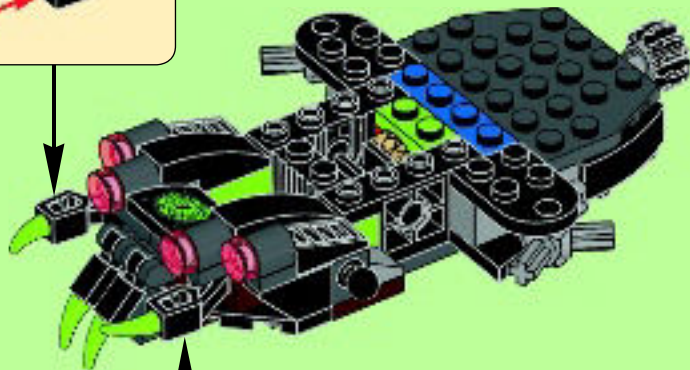
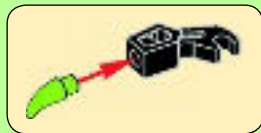



26

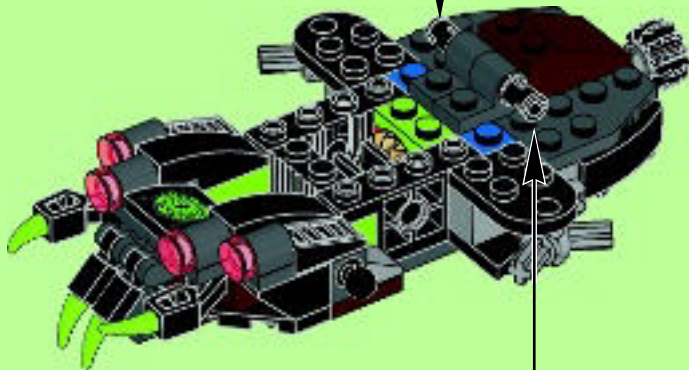



2x

27

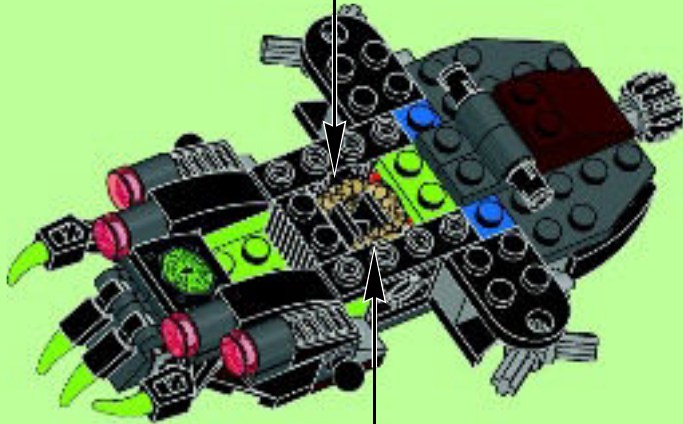



2x



1x

28

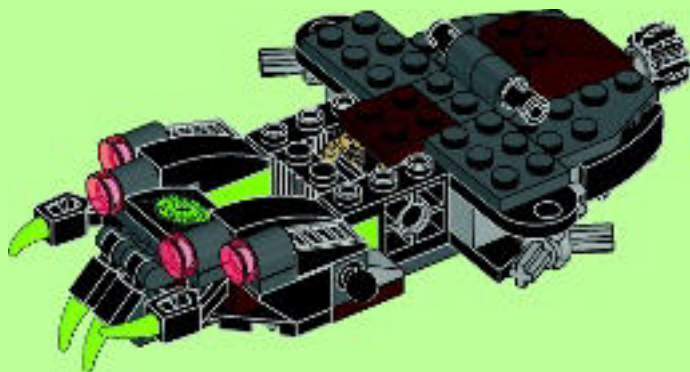

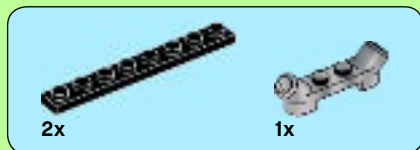

29

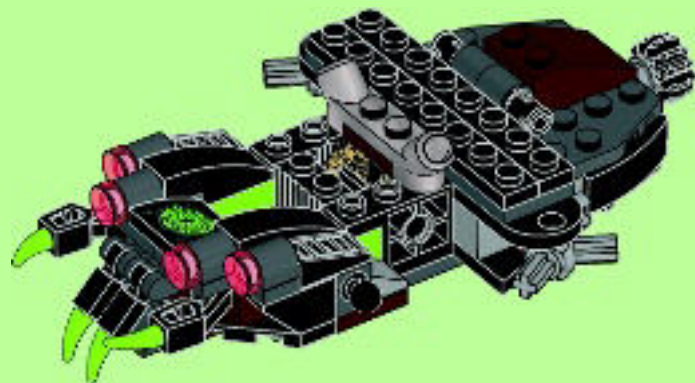



1x



2x



2x

30

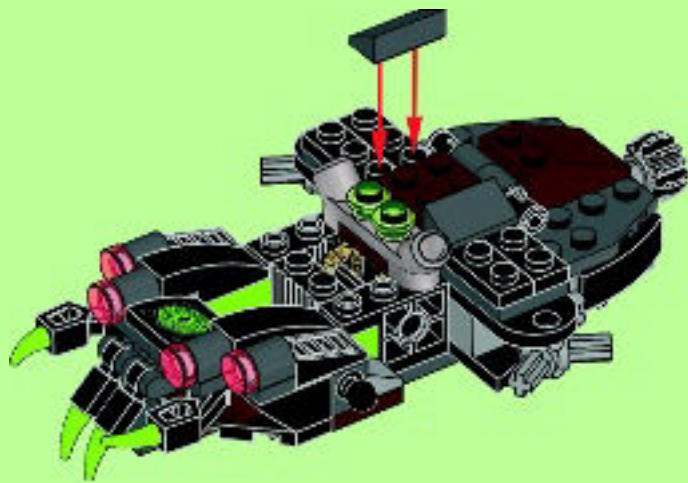



2x

31

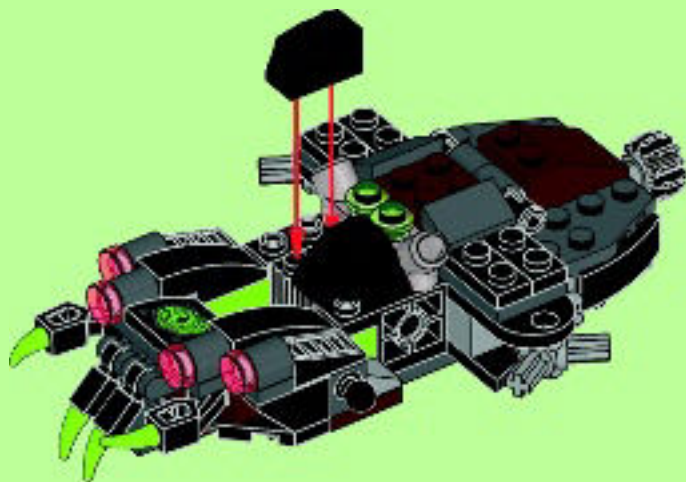

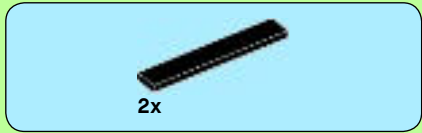

32

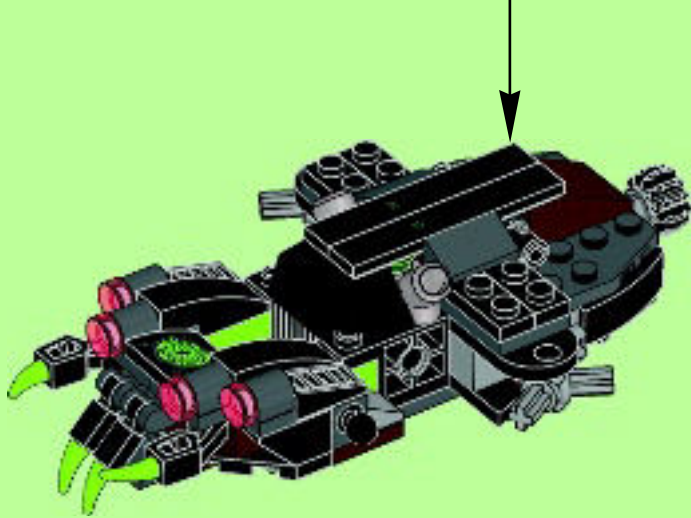
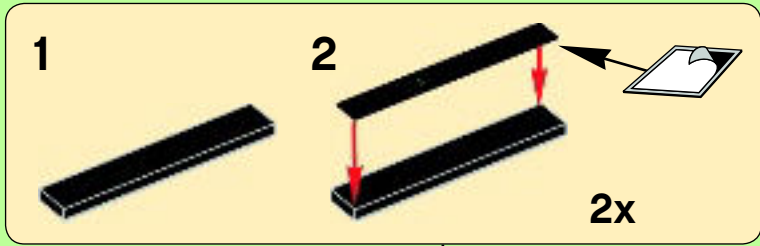



33

1

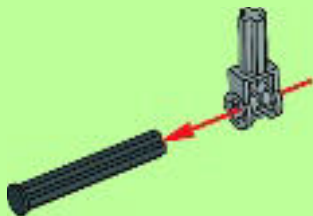

2

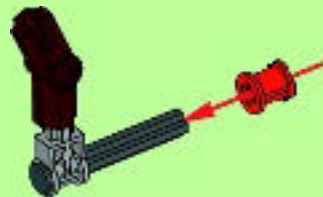

2x

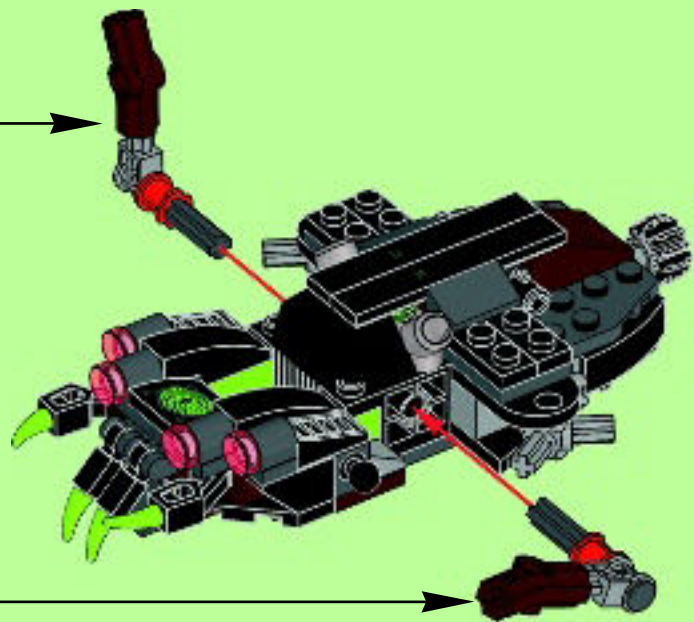



2x



2x

34



2x

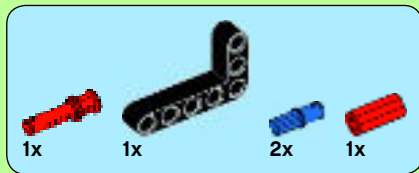
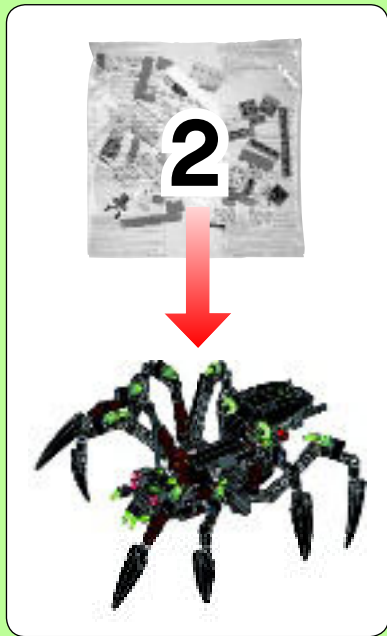

35

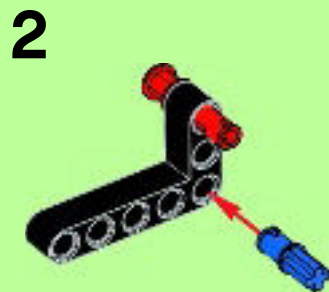

3

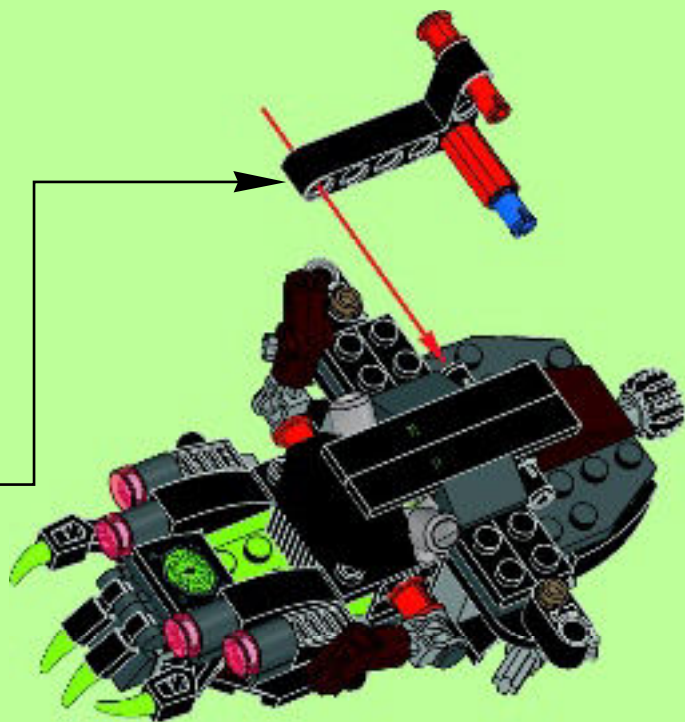
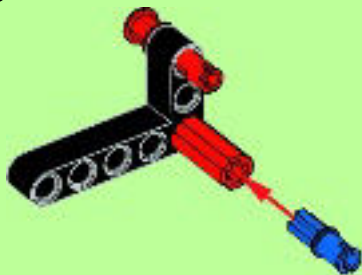



2x

1

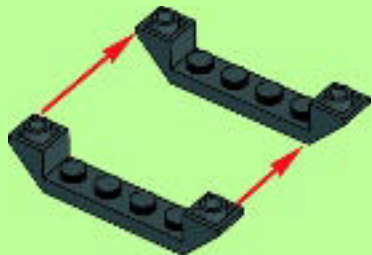

2x

2





2x



4x

3

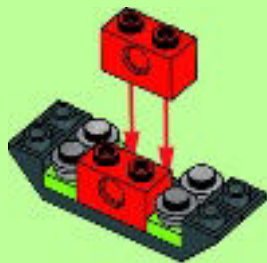

2x



4x

4





5

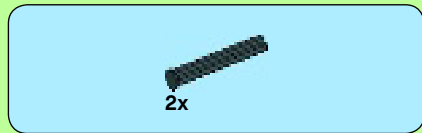
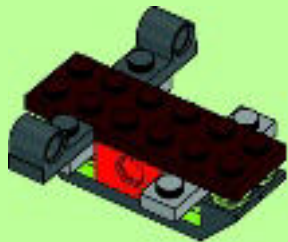

6

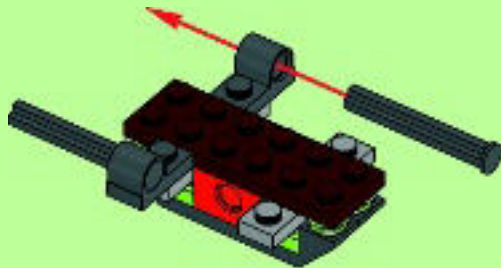



2x

7

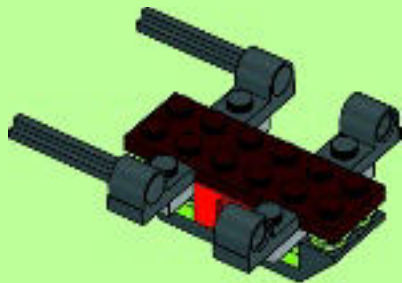

2x

8

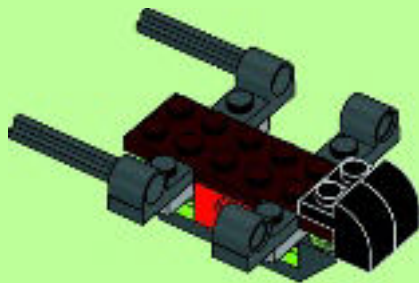



9



10

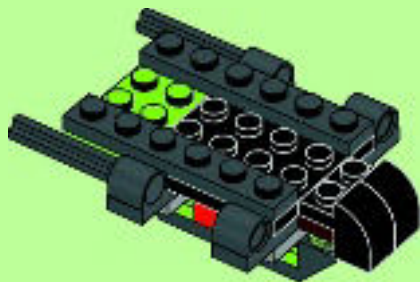

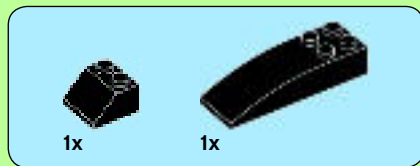

11

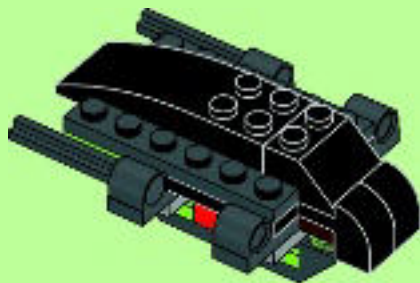

12

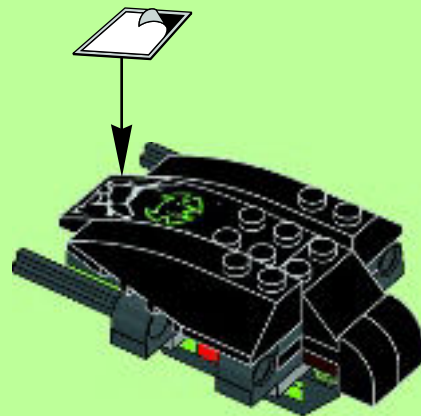



1x

13

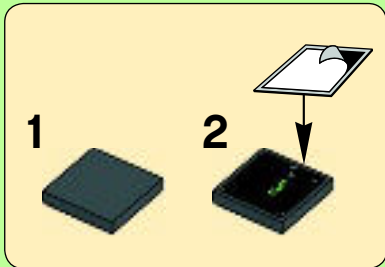

2x



2x

14

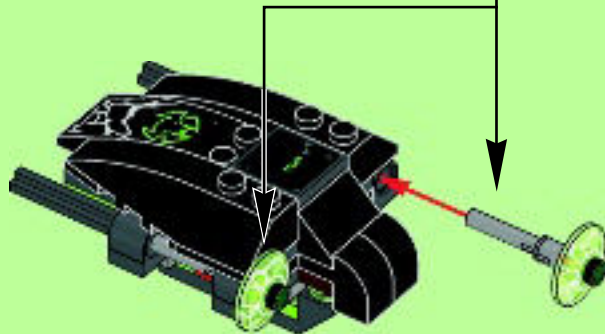

36

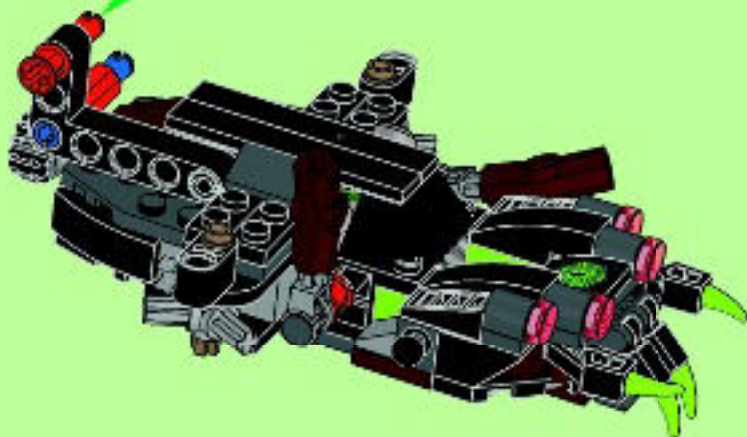



1x

37

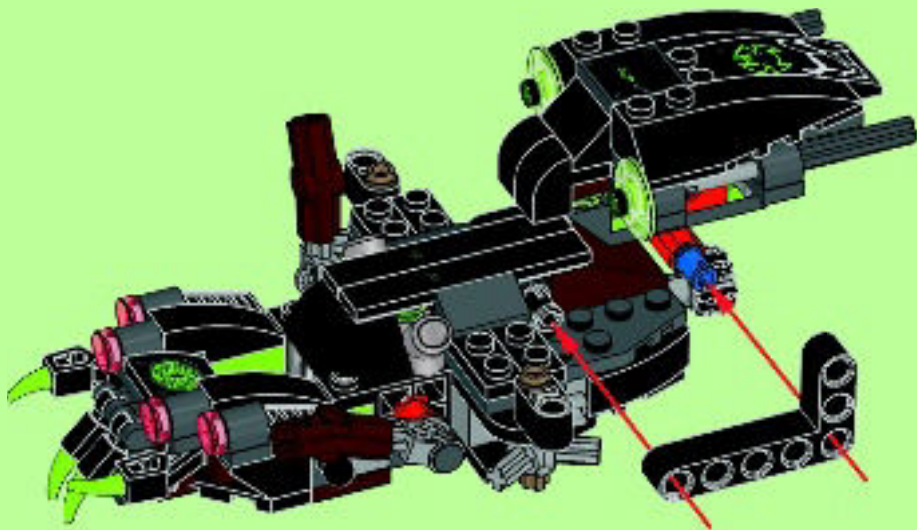



1x

38

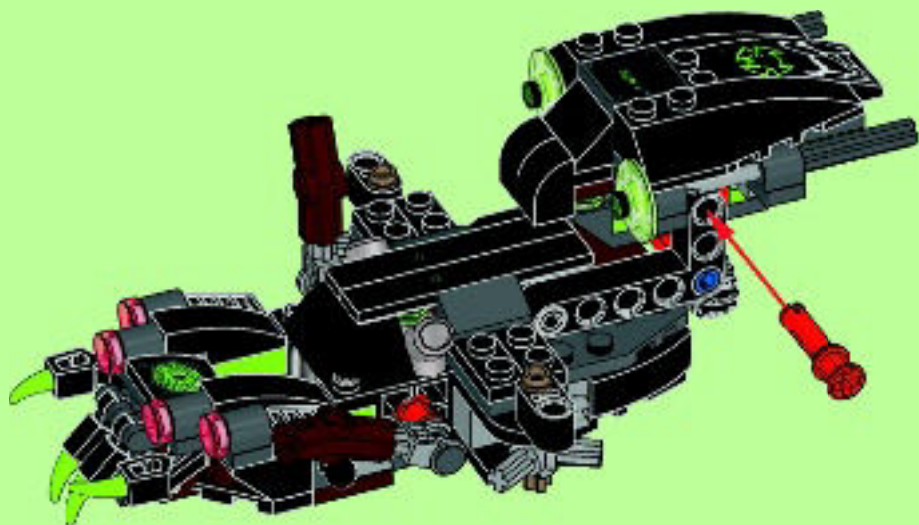

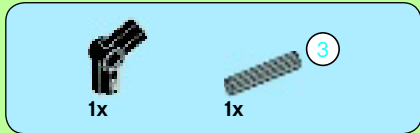

1

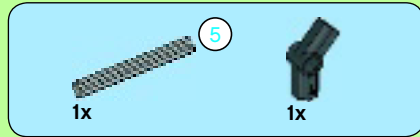
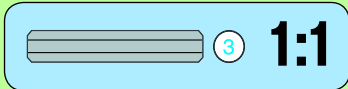
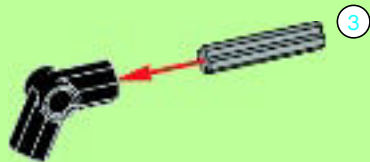

2

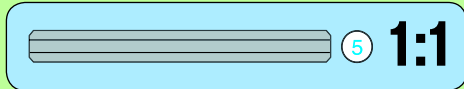
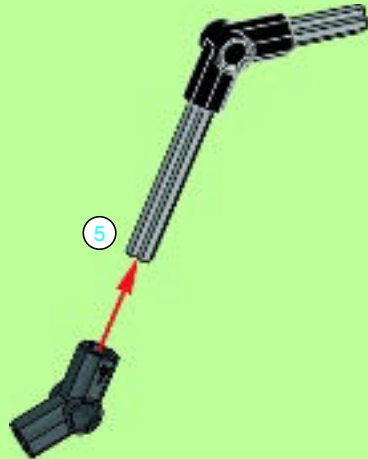



1x



1x

3

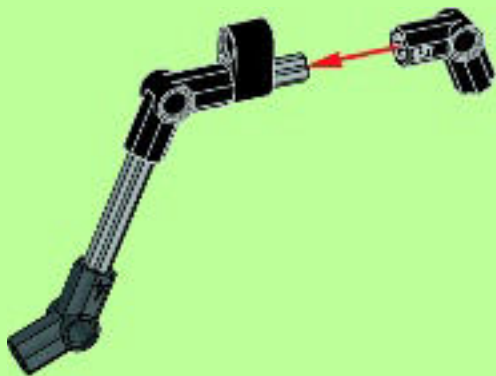

1x

4

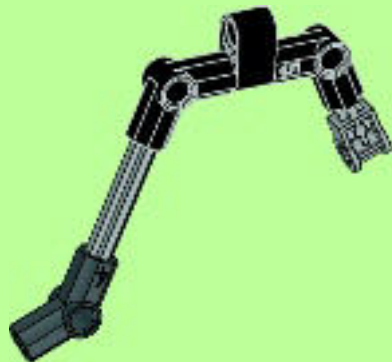



5

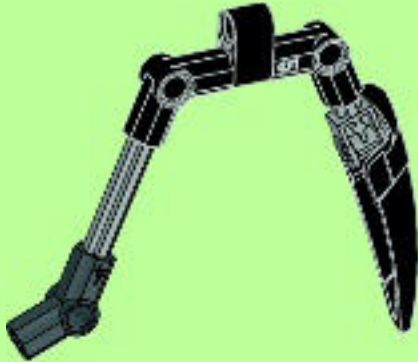

6

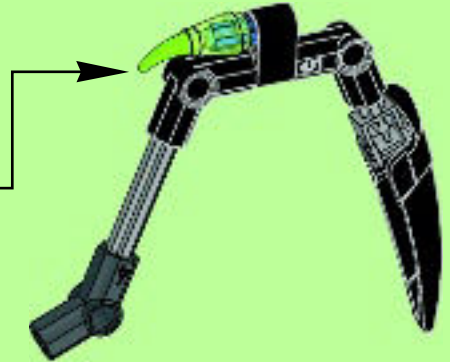

4x

39





8x

40





4x

41



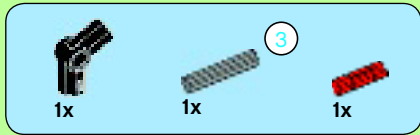

1

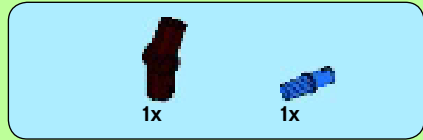
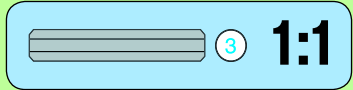
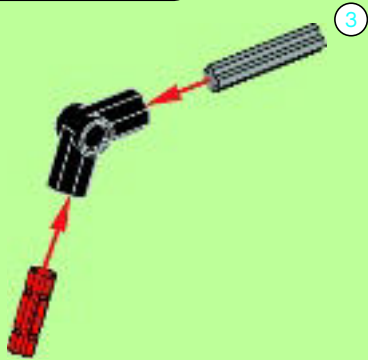

2





1x



1x

3

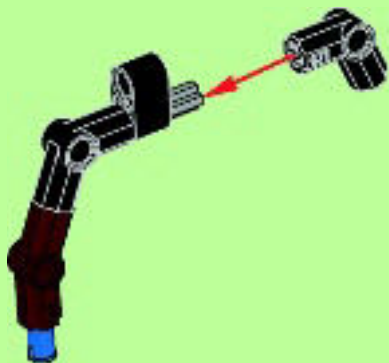

1x



1x



1x

4

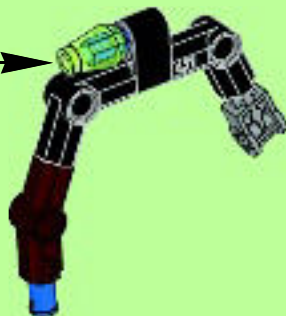
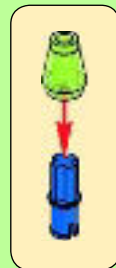



5



2x

42

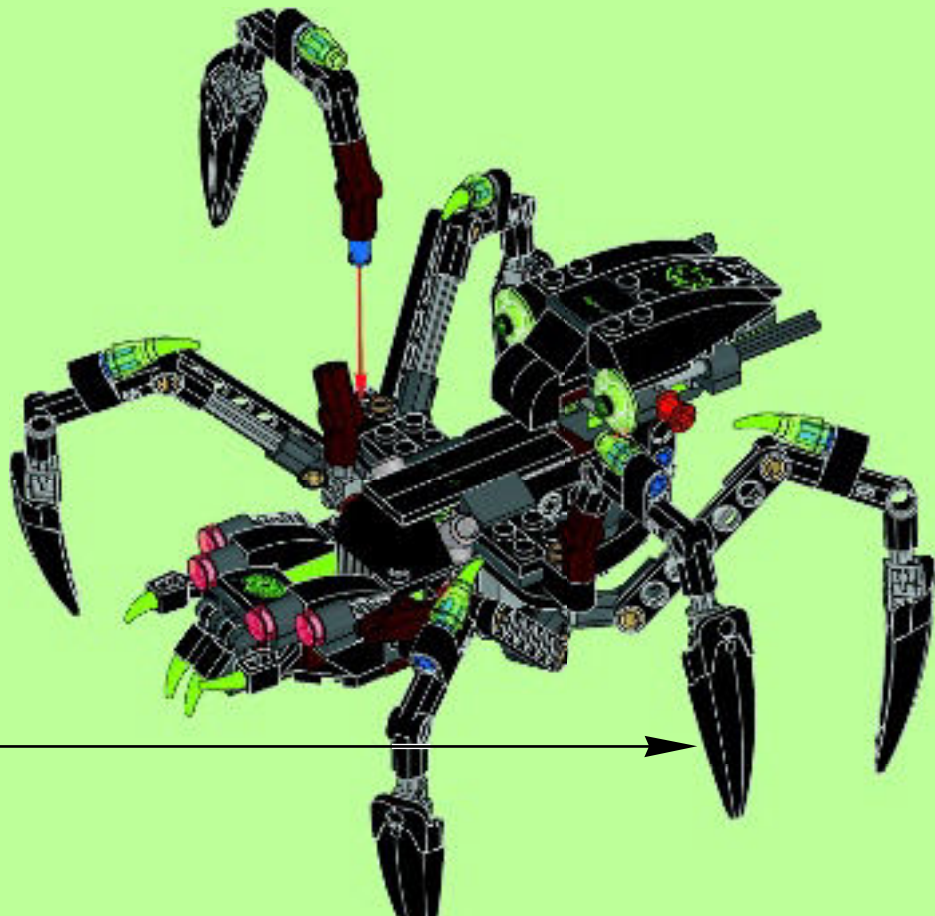

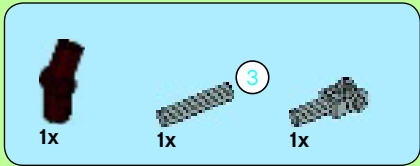

1

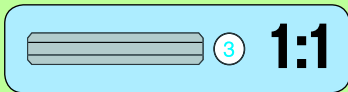
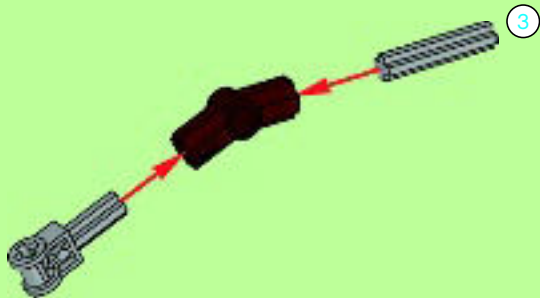

2

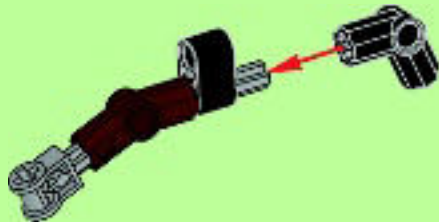



1x



1x

3

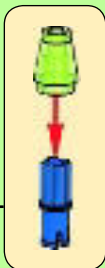

4

1:1



1x



1x

4

4

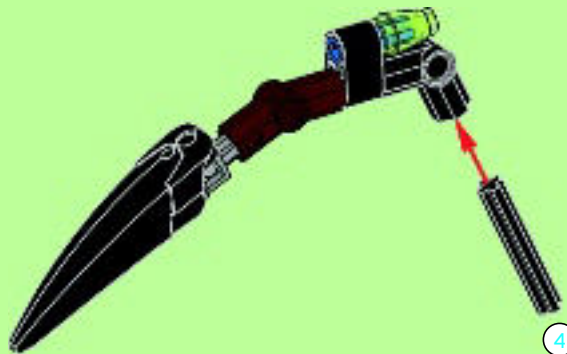

4

2x

43



44

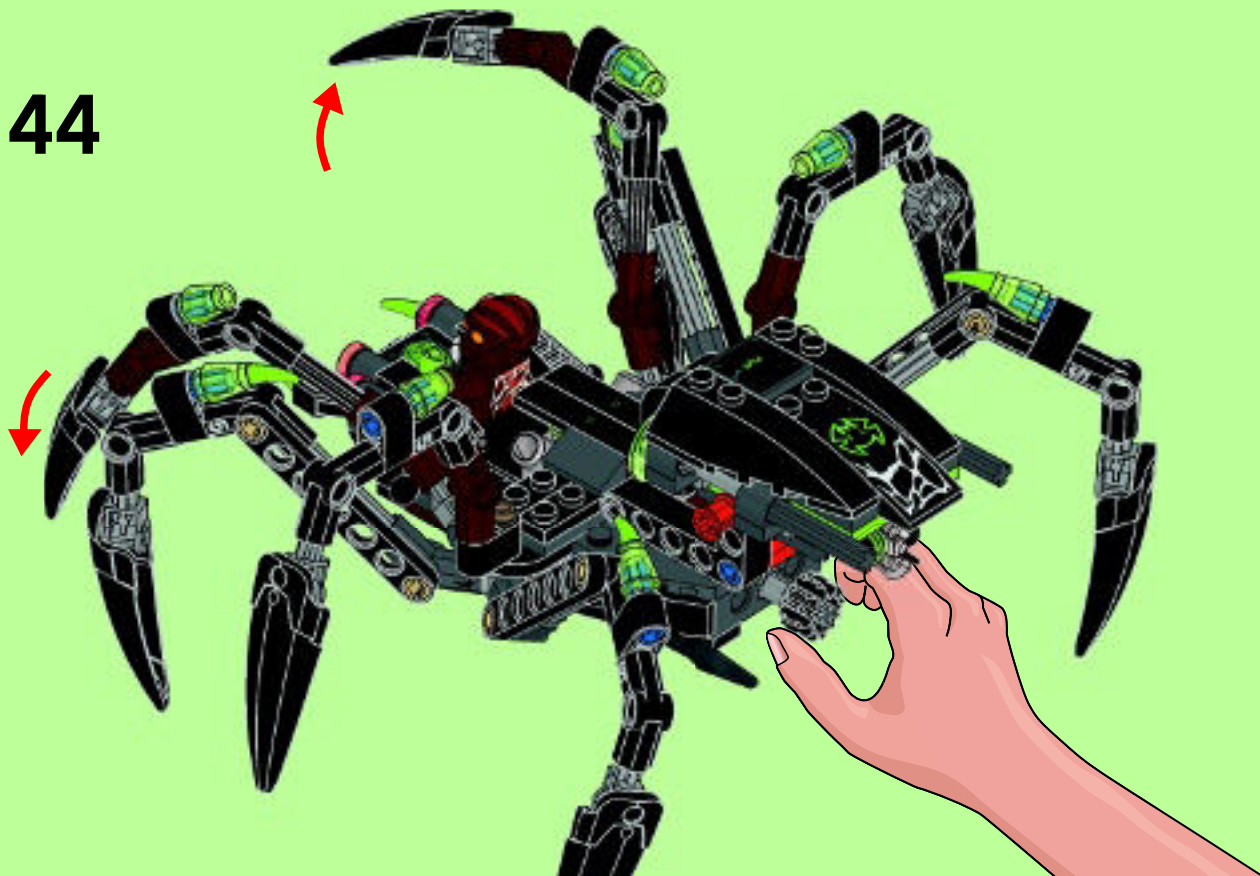





1x
6006221



2x
6024495



8x
6013938



3x
4565452



3x
370021



1x
4593768



2x
4227155



2x
4142865



2x
4513174



4x
4140806



1x
371023



12x
4206482



1x
302124



2x
4114584



1x
4239601



1x
287726



2x
366526



1x
303926



2x
609126



1x
6053077



4x
4251161



1x
4180548

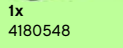

1x
4160108



1x
4160130



2x
663626



1x
4243819

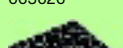

2x
346026

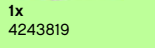

2x
6030718



2x
317626



1x
4283047



1x
4283046



1x
241926



1x
6055053



1x
6035176



1x
6035141



2x
6006739



1x
6051527



1x
4113209



2x
4541191



2x
6015891

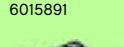

1x
4500902



2x
4142823



10x
6006140



4x
4114295

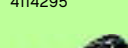

8x
6056377



2x
4184169



2x
4121715



14x
4107084



2x
370526



1x
4177431



1x
241928



1x
6050929



4x
4646864



1x
6022171



1x
4163917



1x
6019570



2x
4166093



2x
4212454



4x
4164037

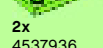

2x
4537936



8x
4579250



2x
6031821



2x
4225823



1x
4216625



4x
4216695

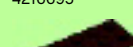

2x
4211247



1x
4262974



1x
6057376



1x
6057369



1x
6057365



1x
6050817



6x
4610666



2x
4535764



4x
4211440



2x
4521921



1x
4565393



2x
4211445



2x
4598526



1x
4654582



1x
6055050



2x
4520320



4x
4211483



2x
4211622



2x
4502595



9x
4211815



10x
4211536



4x
4211639



2x
4210639



1x
4213607



3x
4567887



2x
4294180



1x
4211055



2x
4211043



2x
4211056



1x
4211061



10x
6019987



2x
4521187



1x
4521572



4x
4210688



4x
4560177



1x
4508553



2x
6034202



8x
6053084



2x
6055154



9x
6057034



4x
4633691



1x
6037878



1x
6055647



1x
6035010



1x
4632100



1x
4614336



Customer Service
Kundenservice
Service Consommateurs
Servicio Al Consumidor
LEGO.com/service or dial

00800 5346 5555 :     
1-800-422-5346 :  



LEGENDS OF

CHIMA

70124



70129



70130



70137



70131



70132



LEGO.COM/CHIMA



LEGENDS OF
CHIMATM



LAVAL

70132 70134



LAVERTUS

70129 70134



SHADOWWIND

70140



ERIS

70128 70133
70139



RINONA

70131



ROGON

70131 70133



CRAGGER

70132



GORZAN

70130 70136



SCORM
70132



SCUTTER
70129



SCOLDER
70140



BRAPTOR
70128



SPARACON
70131



SPARRATUS
70130 70138



SPINLYN
70133



BLISTA
70134 70137



70132



70131



70130



70129



70128



70127



70126



70125



70124



70123



70140



70139



70138



70137



70136

LEGO

LEGENDS OF

CHIMA™



LEGO.COM/CHIMA



LEGENDS OF
CHIMA™

LEGO.COM/CHIMA

**JOIN
THE QUEST!**

DAS ABENTEUER ERWARTET DICH!
RE-JOINS LA QUETE!
¡PARTICIPA EN LA AVENTURA!
JUNTA-TE A MISSAU!
SEGITS TE IS A KERESÉSBEN!



SCAN

SCANNEN · SCANNE
ESCANER · FAZ SCAN
OLVASD BE



[http://www.lego.com/
Quest844](http://www.lego.com/Quest844)



WATCH

ANSEHEN · REGARDER
MIRA · VÊ · NÉZD MEG



BILLUND • DEUTSCHLAND • MALAYSIA • WINDSOR



4D MOVIE
EXPERIENCE



MANCHESTER • TOKYO • BERLIN • OBERHAUSEN



**FIND OUT MORE AND GET
SPECIAL OFFERS
AT LEGOLAND-CHIMA.COM**



KIDS GO FREE

with full paid adult ticket

Purchase at LEGOLAND-CHIMA.com

See website for terms and offer details.

FREIER KINDER-EINTRITT

in Verbindung mit einem voll
zahlenden Erwachsenen.

Erhältlich bei LEGOLAND-CHIMA.com

Siehe Webseite für alle Angebotsdetails und Konditionen.

ENTRÉE GRATUITE POUR LES ENFANTS

pour l'achat d'un billet adulte

Billets disponibles à la vente sur

LEGOLAND-CHIMA.com

Conditions et détails de l'offre
disponibles sur le site Internet



club™

Free*! Gratuit!

* Paid subscription in Australia and New Zealand.
Abonnement payant en Australie et Nouvelle-Zélande

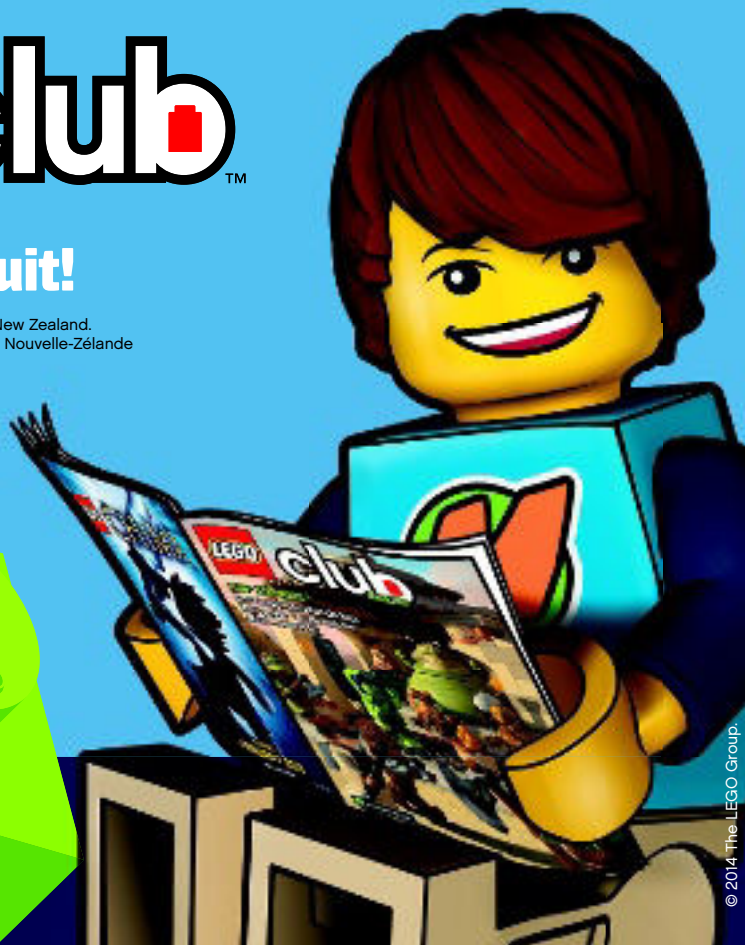

© 2014 The LEGO Group



LEGO.com/club



WIN!

Go to LEGO.com/productfeedback to fill out a survey for a chance to win a cool LEGO® Product.

No purchase necessary.
Open to all residents where not prohibited.



LEGO.com/productfeedback

GEWINNE!

Nimm an der Umfrage auf LEGO.com/productfeedback teil und hab die Chance ein cooles LEGO® Produkt zu gewinnen!

Die Teilnahme am Gewinnspiel führt zu keinerlei Kaufverpflichtungen. Teilnahme in allen nicht ausgeschlossenen Ländern möglich.

 LEGO.com

6079584

WIN!

Ga naar LEGO.com/productfeedback, vul een enquêteformulier in en maak kans op een cool LEGO® product.

Geen aankoopverplichting.
Iedereen mag deelnemen, uitgezonderd ingezetenden van landen waar een enquêteverbod geldt.

GAGNE!

Visite LEGO.com/productfeedback pour répondre à un questionnaire et avoir une chance de gagner un produit LEGO® très cool!

Aucune obligation d'achat.
Ouvert à tous les résidents des pays autorisés.

当てよう!

LEGO.com/productfeedback にアクセスして、アンケートにご記入ください。当選者にはレゴ®製品を差し上げます。

お買い上げの必要はありません。
禁止されていない限り、すべての皆様にご利用いただけます。

LEGO, the LEGO logo and LEGENDS OF CHIMA are trademarks of the LEGO Group.
©2014 The LEGO Group.